

Technical Data Sheet

SMD PIN Photodiode: PD7430

■ Features

- . Fast response time
- . High photo sensitivity
- . Small junction capacitance
- . Pb free
- . The product itself will remain within RoHS compliant version.

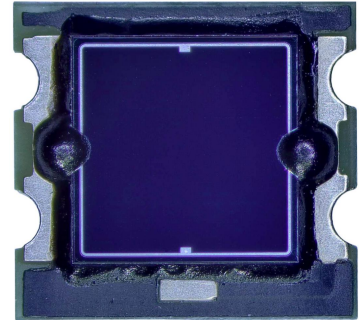

■ Descriptions

PD7430 is a high speed and high sensitive PIN photodiode in a miniature flat top view no lens SMD package . The device is sensitive to visible and infrared radiation.

■ Applications

- . High speed photo detector
- . Industrial electronics
- . Optical communication

Package Dimensions

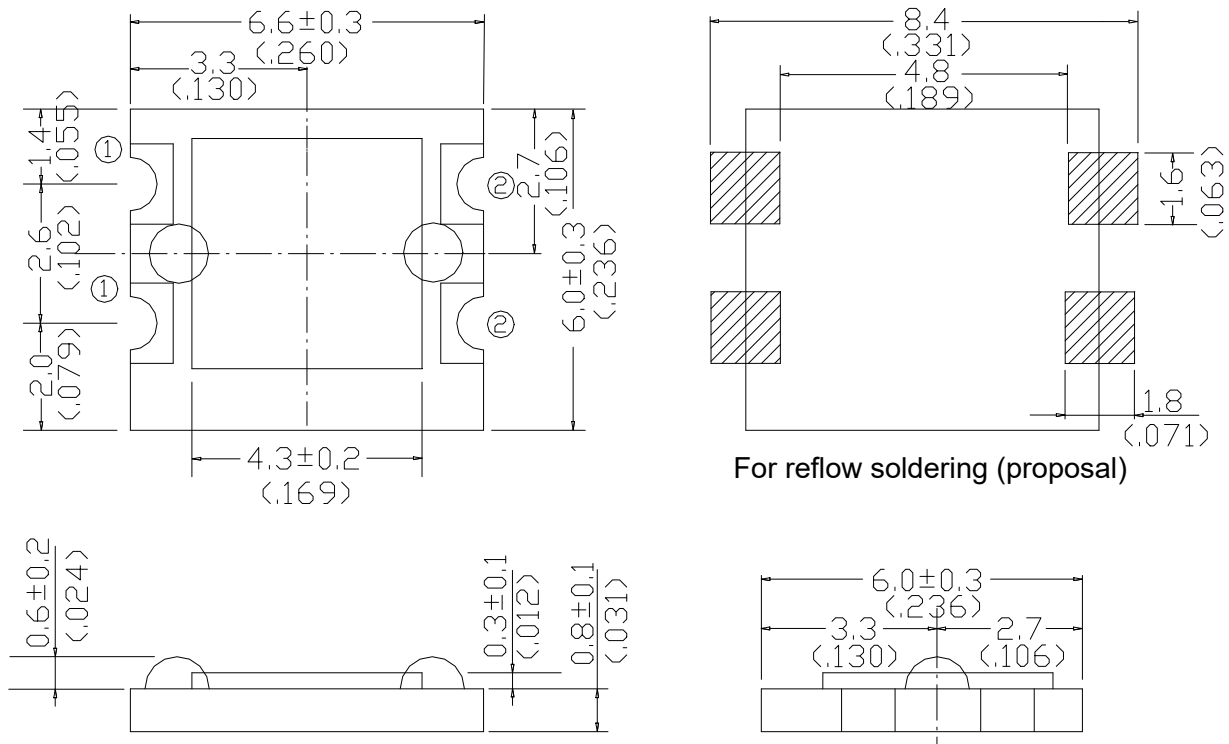

For reflow soldering (proposal)



Note: 1. All dimensions are in millimeters(inches)
2. Tolerances unless dimensions ± 0.25 mm (.01")

Absolute Maximum Ratings (Ta=25°C)

Parameter	Symbol	Rating	Units
Reverse Voltage	VR	30	V
Power Dissipation	Pd	150	mW
Soldering Temperature	Tsol	260	°C
Operating Temperature	Topr	-25 ~ +100	°C
Storage Temperature	Tstg	-40 ~ +100	°C

■ Electro-Optical Characteristics (Ta=25°C)

Parameter	Symbol	Condition	Min.	Typ.	Max.	Units
Range of Spectral Bandwidth	$\lambda_{0.5}$	----	430	----	1100	nm
Wavelength of Peak Sensitivity	λ_p	----	----	940	----	nm
Open-Circuit Voltage	V _{oc}	Note(1)	----	0.32	----	V
Short- Circuit Current	I _{sc}	Note(1)	70	90	----	μ A
Reverse Light Current	I _L	Note(1) V _R =5V	70	90	----	μ A
Dark Current	I _d	Ee=0m W/cm ² V _R =10V	----	----	10	nA
Reverse Breakdown Voltage	BV _R	Ee=0m W/cm ² I _R =100 μ A	30	---	----	V
Total Capacitance	C _t	Ee=0m W/cm ² V _R =3V f=1MHZ	----	100	----	pF
Rise/Fall Time	t _r /t _f	V _R =10V R _L =1K Ω		100		nS

Note(1): Parallel light of 1000 Lux illumination is applied by a Tungsten lamp of 2856K

■ Typical Electro-Optical Characteristics Curves

Fig.1 Power Dissipation vs. Ambient Temperature

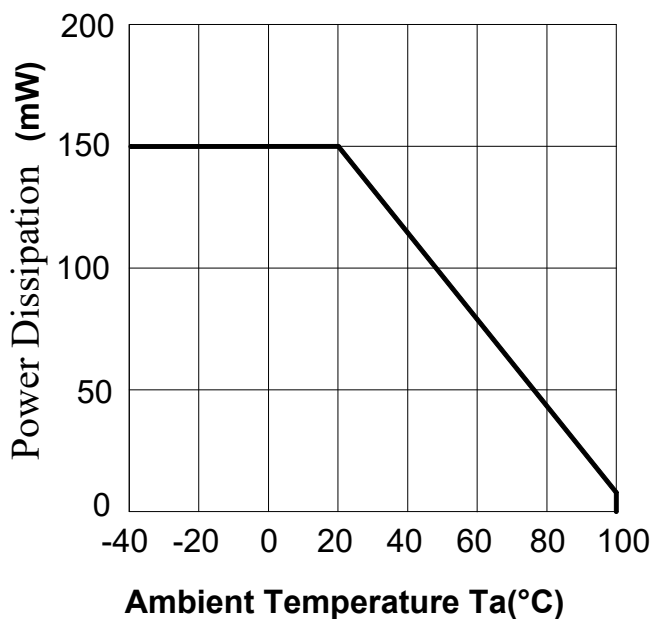

Fig.2 Spectral Sensitivity

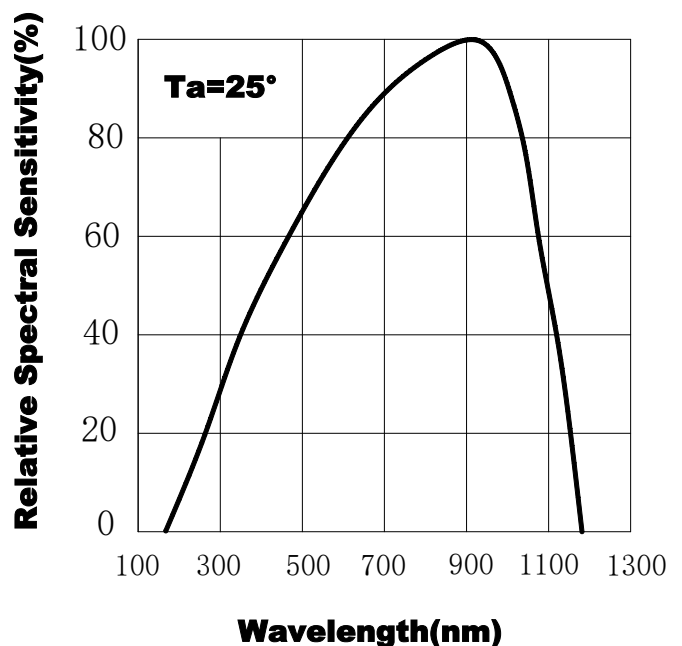

Fig.3 Dark Current vs. Ambient Temperature

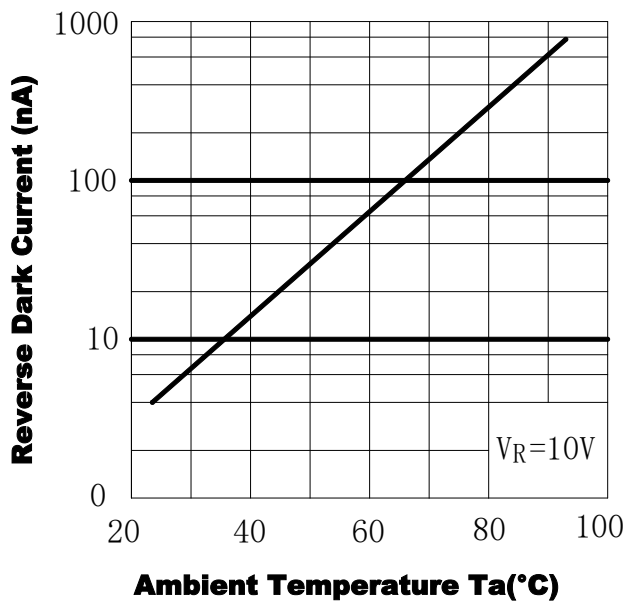

Fig.4 Reverse Light Current vs. E_e

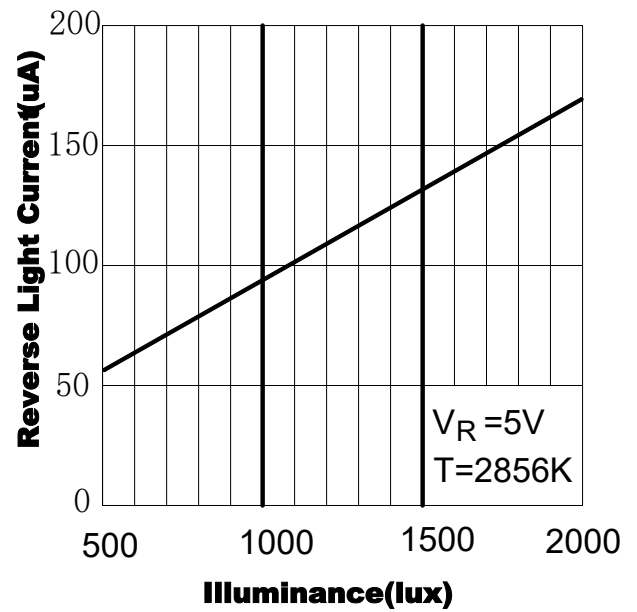

Fig.5 Terminal Capacitance vs. Reverse Voltage

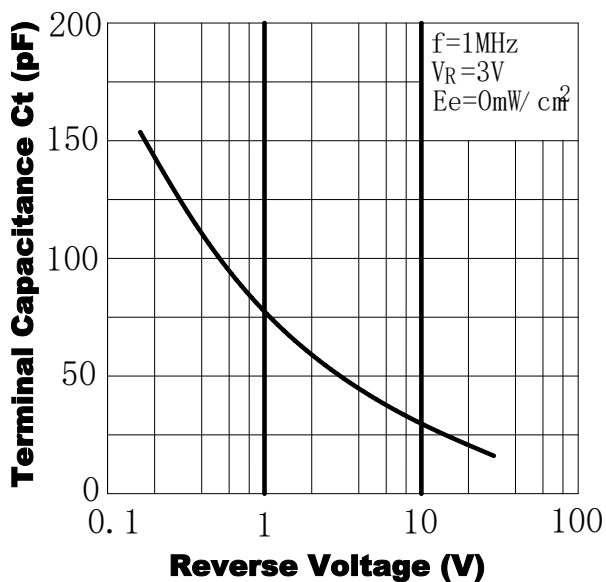
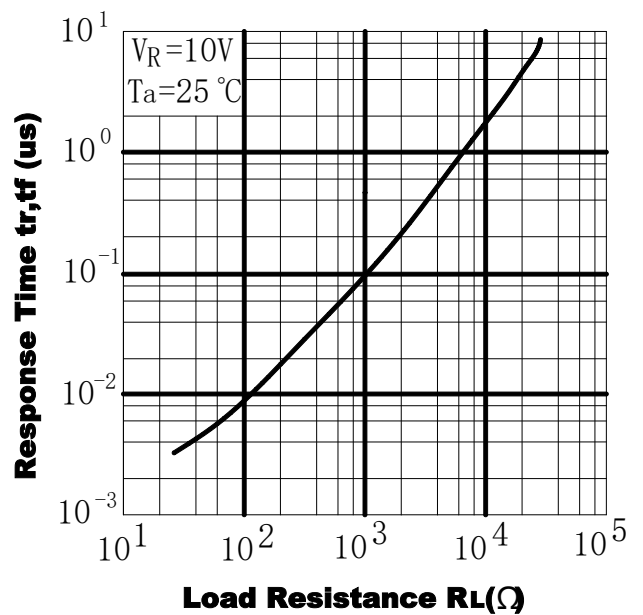
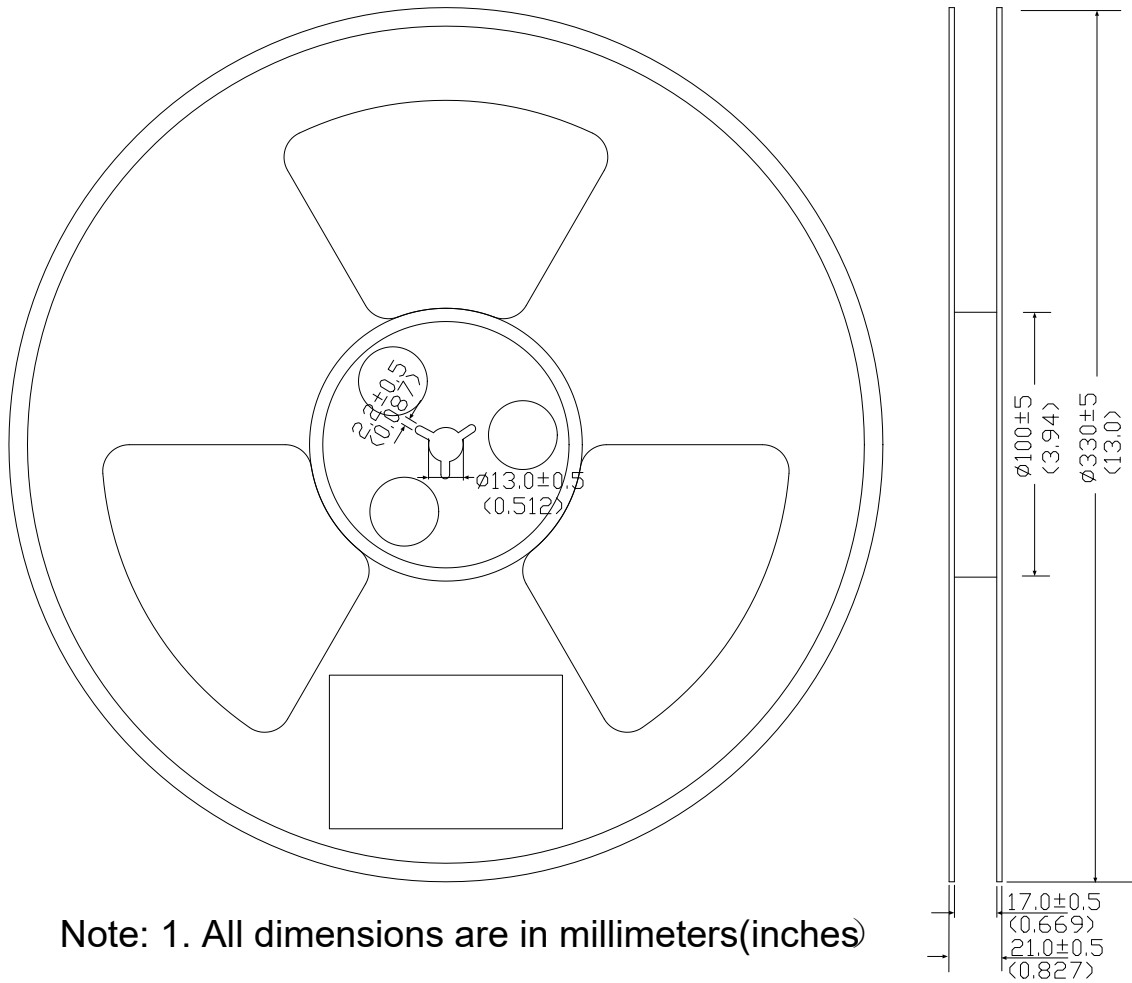

Fig.6 Response Time vs. Load Resistance



■ Packing Dimensions



Note: 1. All dimensions are in millimeters(inches)

■ Carrier Tape Dimensions (Quantity: 1000 pcs/reel)

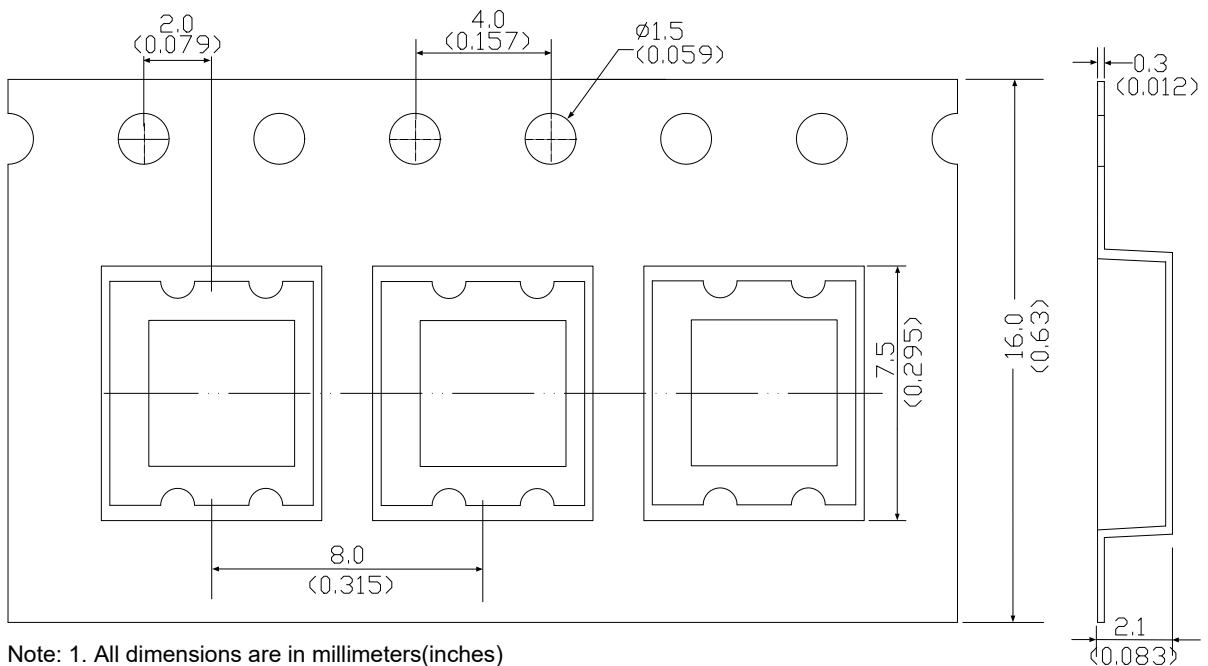

Note: 1. All dimensions are in millimeters(inches)
 2. Tolerances unless dimensions $\pm 0.1\text{mm}(.004\text{'})$

■ Notes

1. Above specification may be changed without notice. SHUGUAN will reserve authority on material change for above specification.
2. When using this product, please observe the absolute maximum ratings and the instructions for using outlined in these specification sheets. SHUGUAN assumes no responsibility for any damage resulting from use of the product which does not comply with the absolute maximum ratings and the instructions included in these specification sheets.
3. These specification sheets include materials protected under copyright of SHUGUAN corporation. Please don't reproduce or cause anyone to reproduce them without SHUGUAN's consent.
4. This products is bare chip products (wafers or diced chips), Unsealed products are not protected by an external enclosure and so require especially strict care to prevent physical breakage or contamination. It has protective tape, which is removed prior to use.
5. Condensation may form on the chip surface in environments subject to sharp or sudden fluctuations in temperature, so avoid use in such locations.
6. Applying excessive force to the product using a printed circuit board may cause the board to warp. This warping may damage the chip,wires connections, so use caution.
7. Do not let anything come in contact with the chip surface. Though the chip is hard, it is also brittle an easily notched. Sharped or hard items that come in contact with the chip may case cracks or scratches, which can lead to fluctuations in electrical characteristics or poor device reliability.