

Technical Data Sheet

SMD Phototransistor: PT6724C

■ Features

- . Fast response time
- . High photo sensitivity
- . Pb free
- . The product itself will remain within RoHS compliant version.

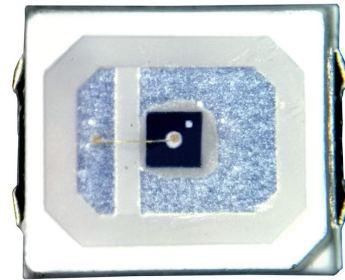

■ Descriptions

PT6724C is a high speed and high sensitive NPN silicon epitaxial planar phototransistor in a miniature flat top view lens SMD package. Due to its water clear epoxy the device is sensitive to visible and infrared radiation.

■ Applications

- . Infrared applied system
- . Security system
- . Camera
- . Optoelectronic switch

■ Package Dimensions

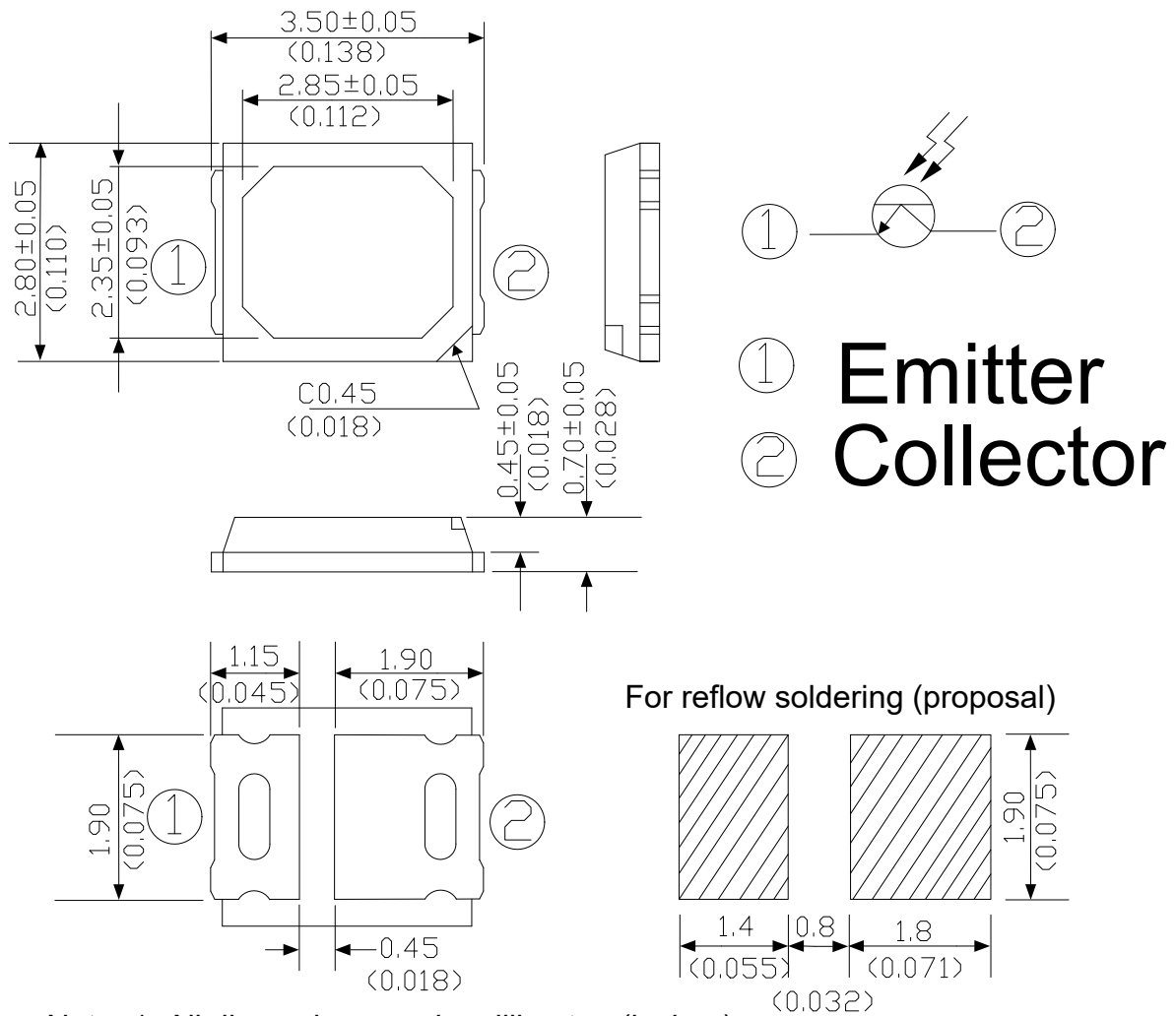

- Note: 1. All dimensions are in millimeters(inches)
 2. Tolerances unless dimensions $\pm 0.1\text{mm}(.004\text{'})$
 3. Suggested pad dimension is just for reference only
 Please modify the pad dimension based on need

■ Absolute Maximum Ratings ($T_a=25^\circ\text{C}$)

Parameter	Symbol	Rating	Units
Collector-Emitter Voltage	V_{CEO}	30	V
Emitter-Collector-Voltage	V_{ECO}	6.5	V
Collector Current	I_c	20	mA
Power Dissipation at (or below) 25°C Free Air Temperature	P_c	75	mW
Lead Soldering Temperature	T_{sol}	260	°C
Operating Temperature	T_{opr}	-20 ~ +85	°C
Storage Temperature	T_{stg}	-40 ~ +85	°C

■ Electro-Optical Characteristics (Ta=25°C)

Parameter	Symbol	Condition	Min.	Typ.	Max.	Units
Rang of Spectral Bandwidth	$\lambda_{0.5}$	---	400	--	1100	nm
Wavelength of Peak Sensitivity	λ_p	---	--	940	--	nm
Collector – Emitter Breakdown Voltage	BV_{CEO}	$I_C=100\mu A$ $E_e=0mW/cm^2$	30	--	100	V
Emitter-Collector Breakdown Voltage	BV_{ECO}	$I_E=100\mu A$ $E_e=0mW/cm^2$	6	--	--	V
Collector-Emitter Saturation Voltage	$V_{CE(sat)}$	$I_C=2mA$ $E_e=1mW/cm^2$	--	--	0.3	V
Rise Time	t_r	$V_{CE}=5V$ $I_C=1mA$	--	15	--	μS
Fall Time	t_f	$RL=1000\Omega$	--	15	--	μS
DC Current Amplification Factor	H_{FE}	$V_{CE}=5V$, $I_C=2mA$	1000	--	1800	
Collector Dark Current	I_{CEO}	$E_e=0mW/cm^2$ $V_{CE}=20V$	--	--	100	nA
On State Collector Current	$I_{C(on)}$	$E_e=1mW/cm^2$ $V_{CE}=5V$	0.5	1.5	--	mA

■ Typical Electro-Optical Characteristics Curves

Fig.1 Collector Power Dissipation vs. Ambient Temperature

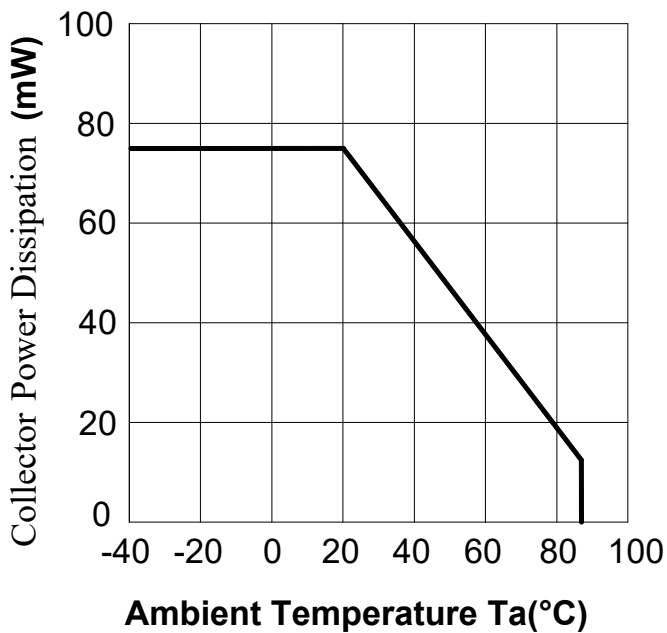

Fig.2 Spectral Sensitivity

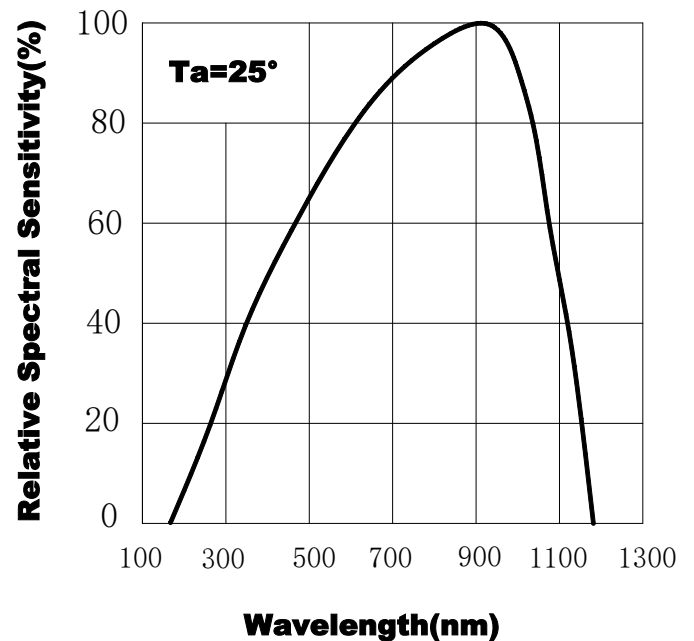

Fig.3 Relative Collector Current vs. Ambient Temperature

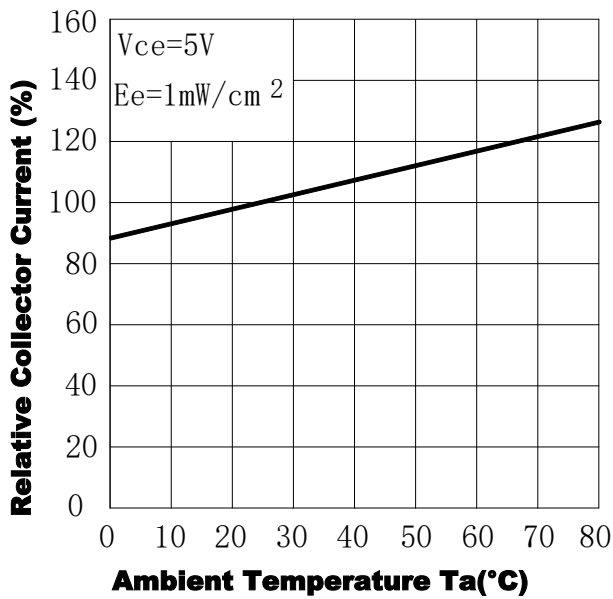

Fig.4 Collector Current vs. Irradiance

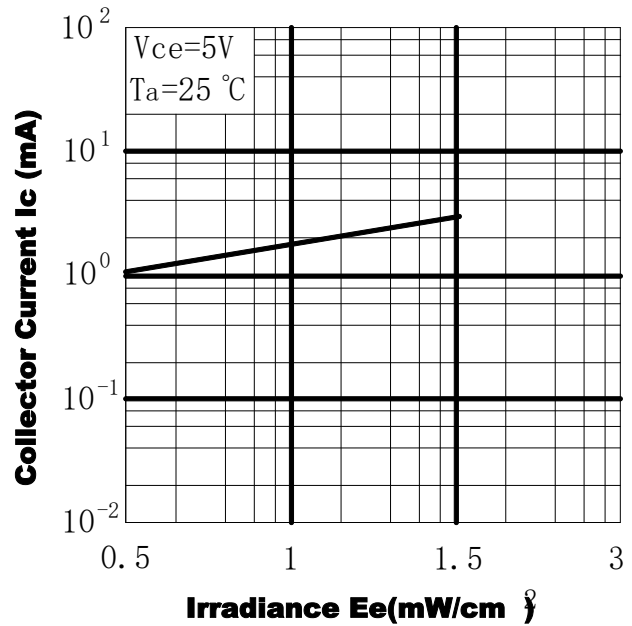

Fig.5 Collector Dark Current vs. Ambient Temperature

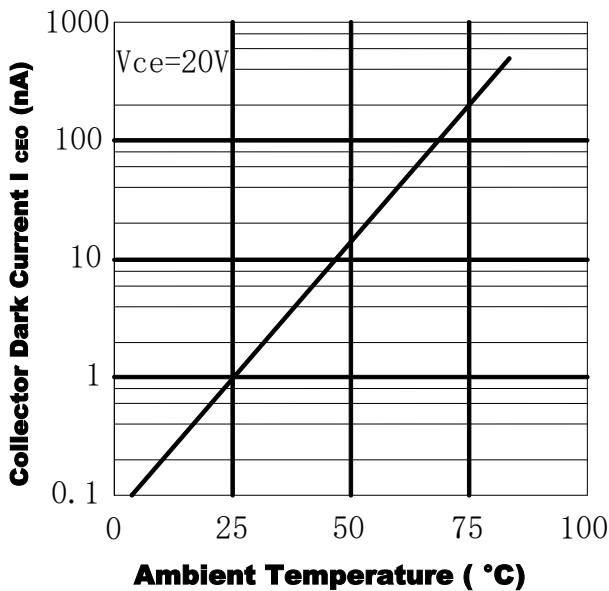
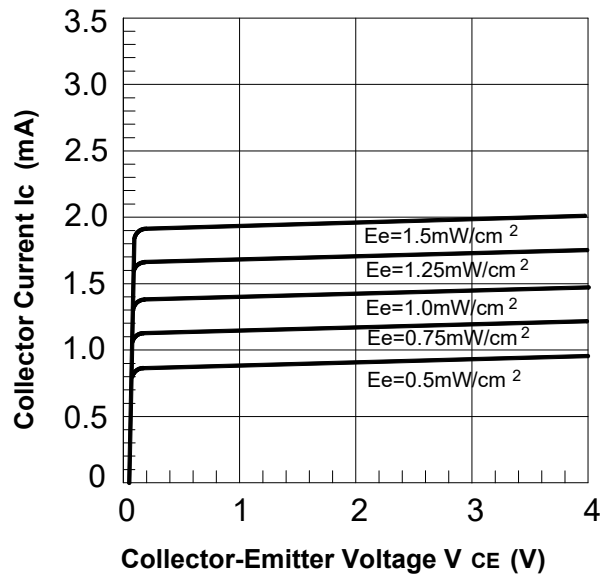
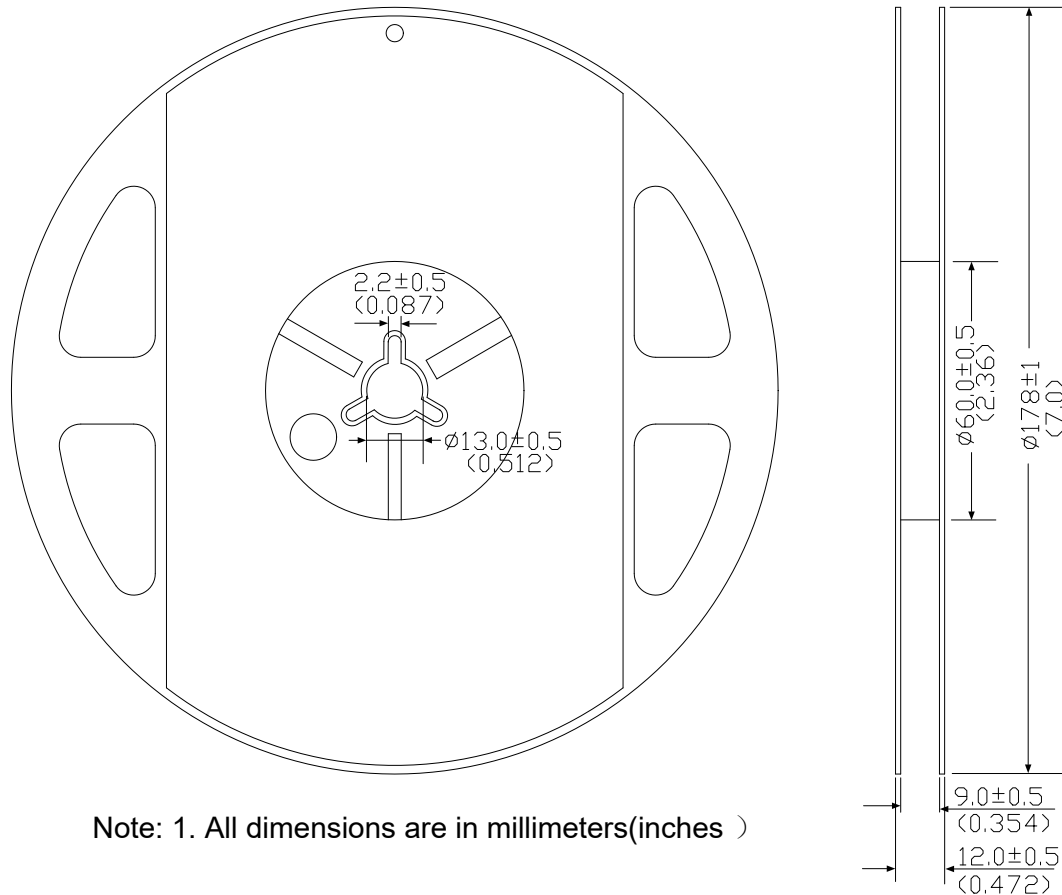

Fig.6 Collector Current vs. Collector-Emitter Voltage



■ Packing Dimensions



■ Carrier Tape Dimensions (Quantity: 4000 pcs/reel)

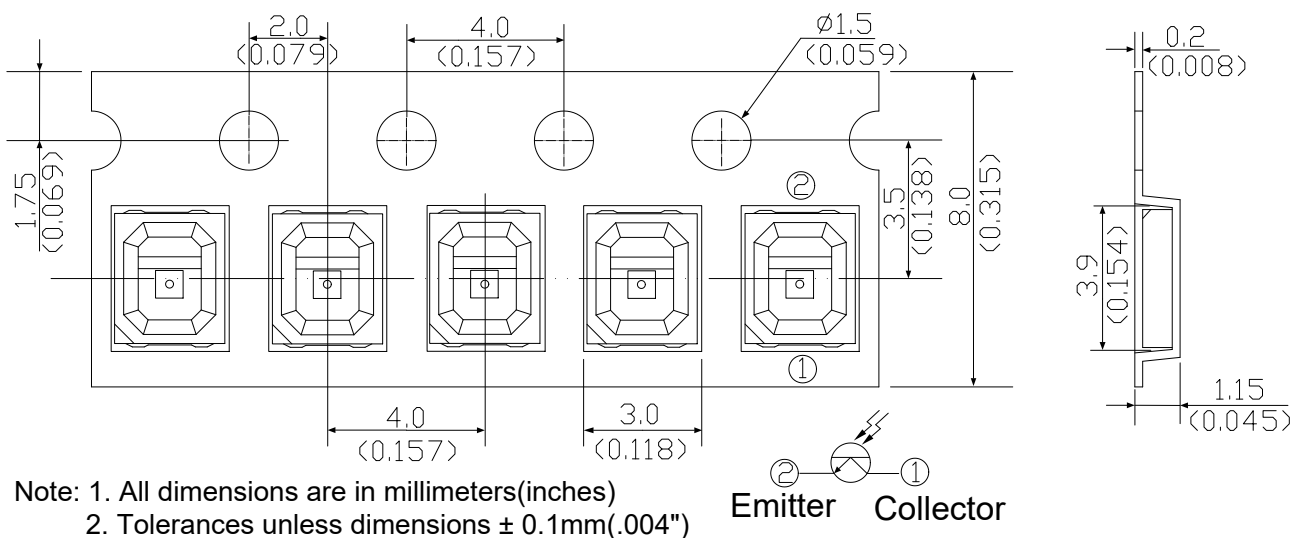

■ Notes

- Above specification may be changed without notice. SHUGUAN will reserve authority on material change for above specification.
- Before using this product, be sure to test it. The use and storage conditions must not exceed the SHENZHEN SHUGUAN ELECTRONIC TECHNOLOGY CO.,LTD. V1.0 2020.04.23

limit parameters specified in this manual. The company will not be responsible for any damage to the product caused by the use of the product beyond the limit parameters.

3. Stored at a temperature not higher than 30° C and humidity not higher than 60%RH, the product shelf life is 6 months. Keeping the product in an airtight container with a desiccant can extend the shelf life of the product to some extent. Poor storage conditions can cause corrosion of product leads or changes in product performance.
4. After opening, the product must be used within 168 hours (recommended working environment temperature not higher than 30 °C, humidity not higher than 60%). If it is not used up, the remaining material must be stored in an environment where the temperature is not higher than 30° C and the humidity is not higher than 10%.
5. For products that have not been soldered, if the hygroscopic agent or packaging fails, or the product does not meet the above valid storage conditions, baking can play a certain performance recovery effect. Baking conditions: $60 \pm 5^{\circ}\text{C}$, duration 96H.
6. Static electricity and surges will cause changes in product characteristics, such as forward voltage reduction, etc. If the situation is serious, it will even damage the product, so effective anti-static measures must be taken during use. All related equipment and machines should be properly grounded, and other measures against static electricity and surges must be taken. The use of anti-static wristbands, anti-static mats, anti-static work clothes, work shoes, gloves, and anti-static containers are all effective measures to prevent static electricity and surges.
7. When designing the circuit, the current passing through the product cannot exceed the specified maximum value, and a current limiting resistor must be used at the same time, otherwise a small voltage change will cause a large current change, which may lead to product damage.
8. Welding should pay special attention to:
 - (1) Manual soldering: the tip temperature of the soldering iron (up to 25W) should not exceed 350° C; the soldering iron must be grounded, and the static electricity should not exceed the range; the soldering time should not exceed 3 seconds.
 - (2) Reflow soldering

. Pb-free solder temperature profile

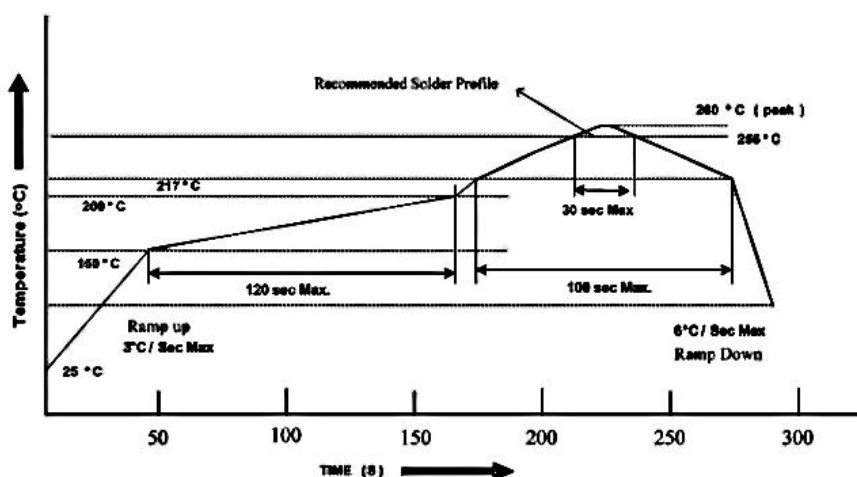

- . Reflow soldering should not be done more than two times.
- . When soldering, do not put stress on the phototransistor during heating
- . After soldering, do not wrap the circuit board.