

Technical Data Sheet

2835 Flat Top Infrared LED: SIR6712

■ Features

- . Dominant Wavelength 940nm
- . Low forward voltage
- . Pb free
- . Compliance with EU REACH
- . The product itself will remain within RoHS compliant version.

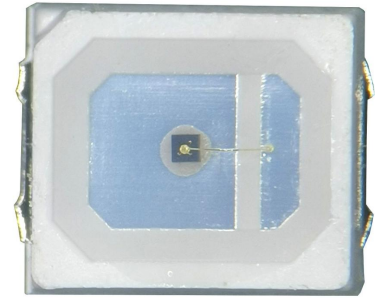

■ Descriptions

The SIR6712 is an infrared emitting diode in miniature SMD package which is molded in a water clear plastic with flat top view lens. The device is spectrally matched silicon photodiode and phototransistor.

■ Applications

- . PCB mounted infrared sensor
- . Infrared emitting for miniature light barrier
- . Optoelectronic switch
- . Smoke detector

Package Dimensions

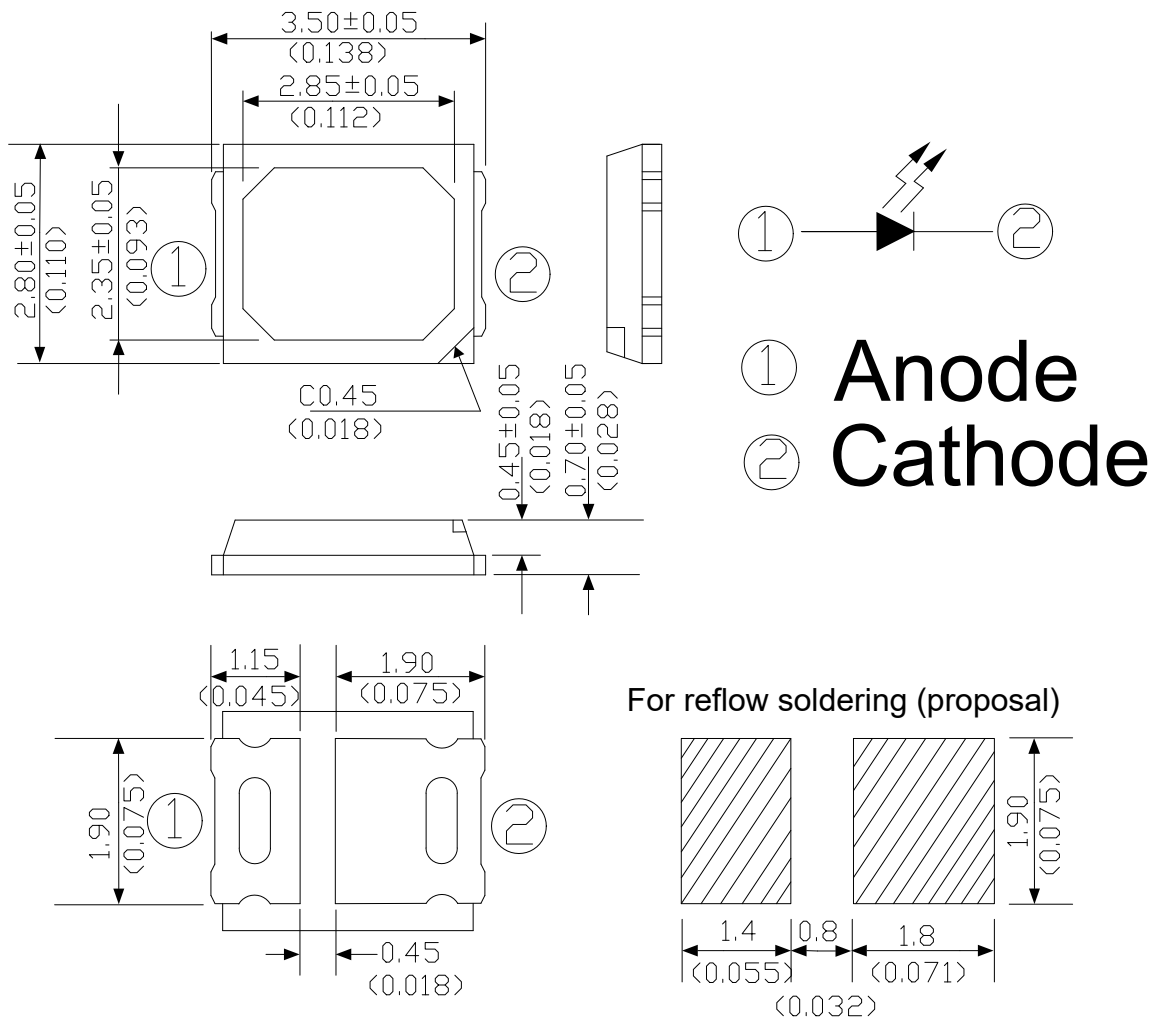

- Note: 1. All dimensions are in millimeters(inches)
 2. Tolerances unless dimensions $\pm 0.1\text{mm}(.004\text{'})$
 3. Suggested pad dimension is just for reference only
 Please modify the pad dimension based on need

Absolute Maximum Ratings ($T_a=25^\circ\text{C}$)

Parameter	Symbol	Rating	Units
Continuous Forward Current	I_F	50	mA
Peak Forward Current*1	I_{PF}	300	mA
Reverse Voltage	V_R	5	V
Power Dissipation	P_d	100	mW
Lead Soldering Temperature*2	T_{sol}	260	$^\circ\text{C}$
Operating Temperature	T_{opr}	-25 ~ +85	$^\circ\text{C}$
Storage Temperature	T_{stg}	-40 ~ +85	$^\circ\text{C}$

Notes: *1: I_{PF} Conditions--Pulse Width $\leq 100 \mu\text{s}$ and Duty $\leq 1\%$.

*2: Soldering time ≤ 5 seconds.

■ Electro-Optical Characteristics (Ta=25°C)

Parameter	Symbol	Condition	Min.	Typ.	Max.	Units
Radiant Intensity	I _e	I _F = 20mA	0.2	0.5	---	mW/sr
Viewing Angle	2θ _{1/2}	I _F = 20mA	---	150	---	deg
Dominant Wavelength	λ _d	I _F = 20mA	---	940	---	nm
Spectrum Radiation Bandwidth	Δλ	I _F = 20mA	---	45	---	nm
Forward Voltage	V _F	I _F = 20mA	---	1.2	1.5	V
Reverse Current	I _R	V _R = 5V	---	---	10	μA

■ Typical Electro-Optical Characteristics Curves

Fig.1 Forward Current vs. Ambient Temperature

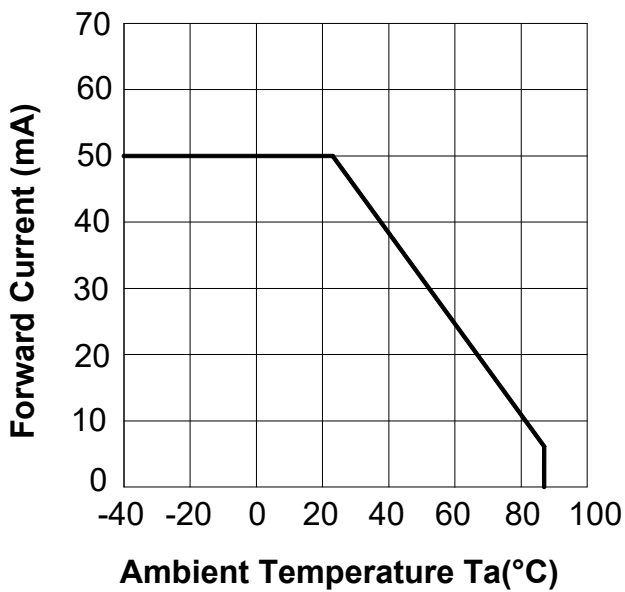

Fig.2 Spectral Distribution

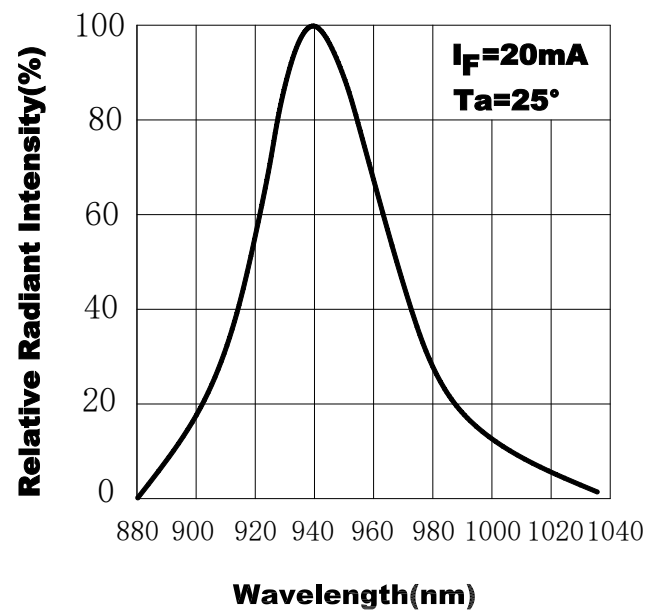

Fig.3 Peak Emission Wavelength vs. Ambient Temperature

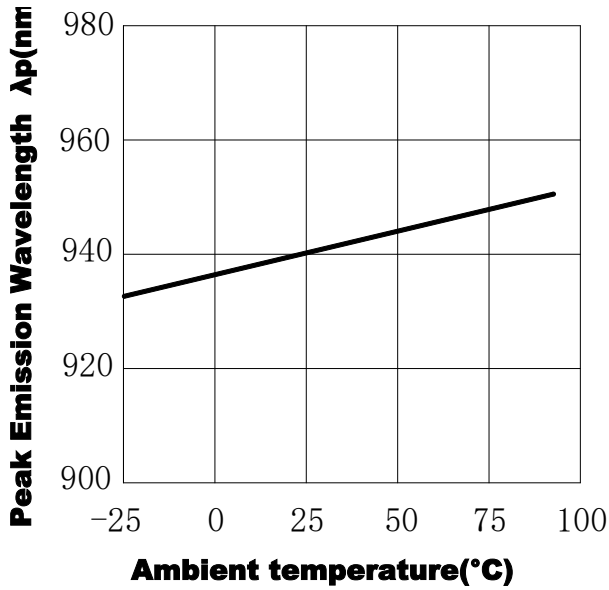

Fig.4 Forward Current vs. Forward Voltage

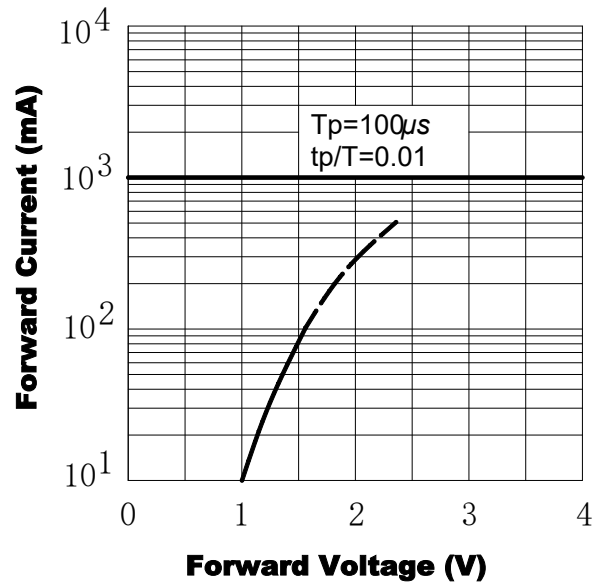

Fig.5 Radiant Intensity vs. Forward Current

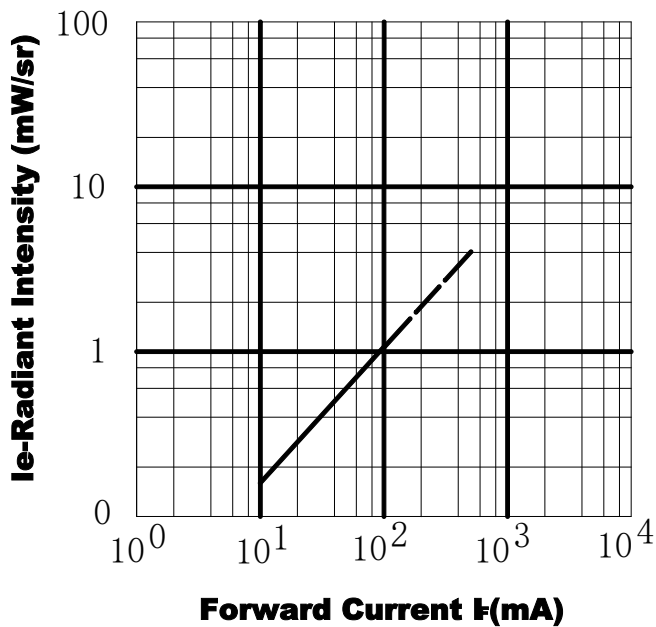

Fig.6 Relative Radiant Intensity vs. Angular Displacement

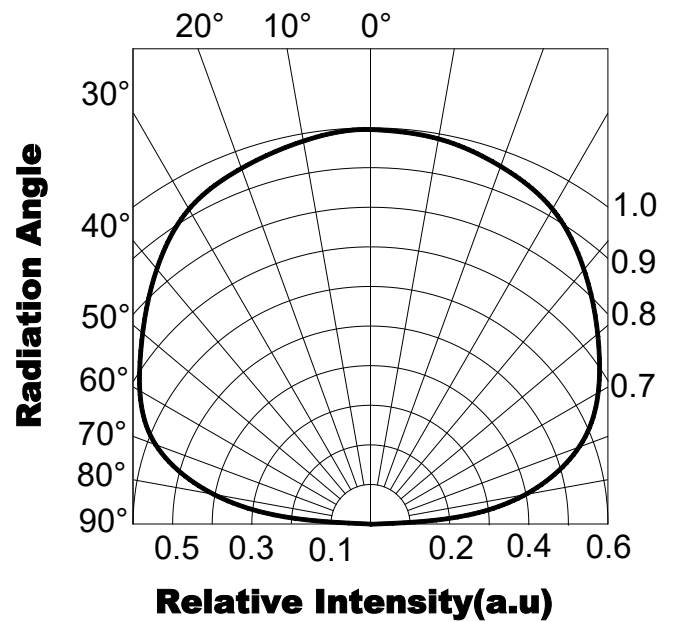
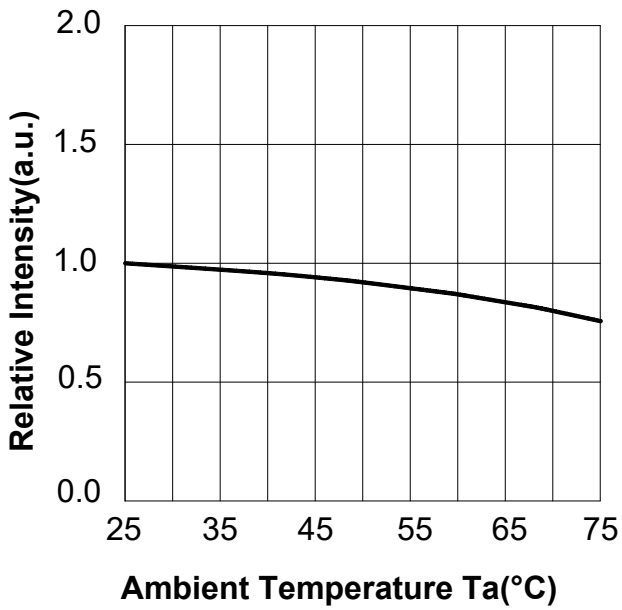
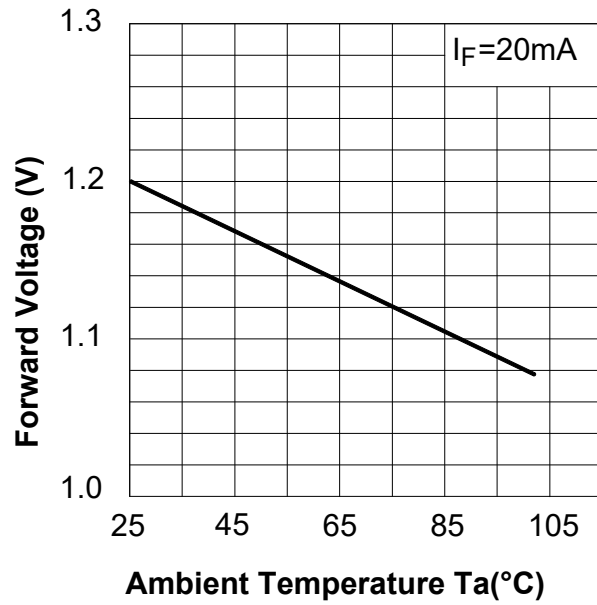
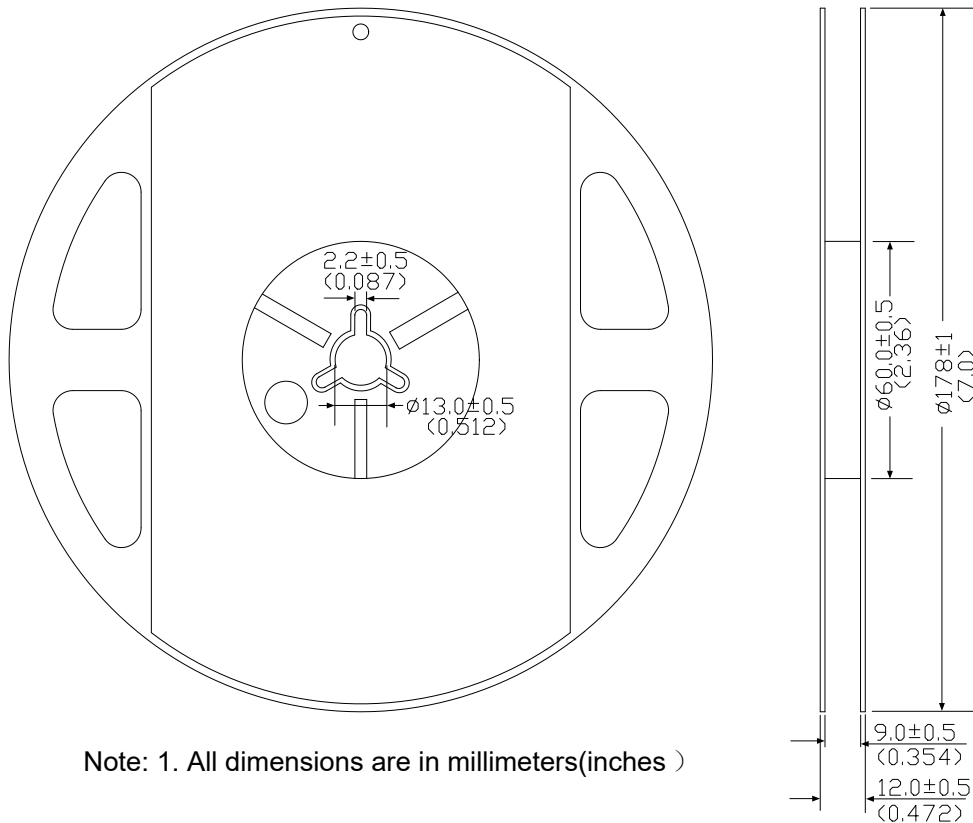
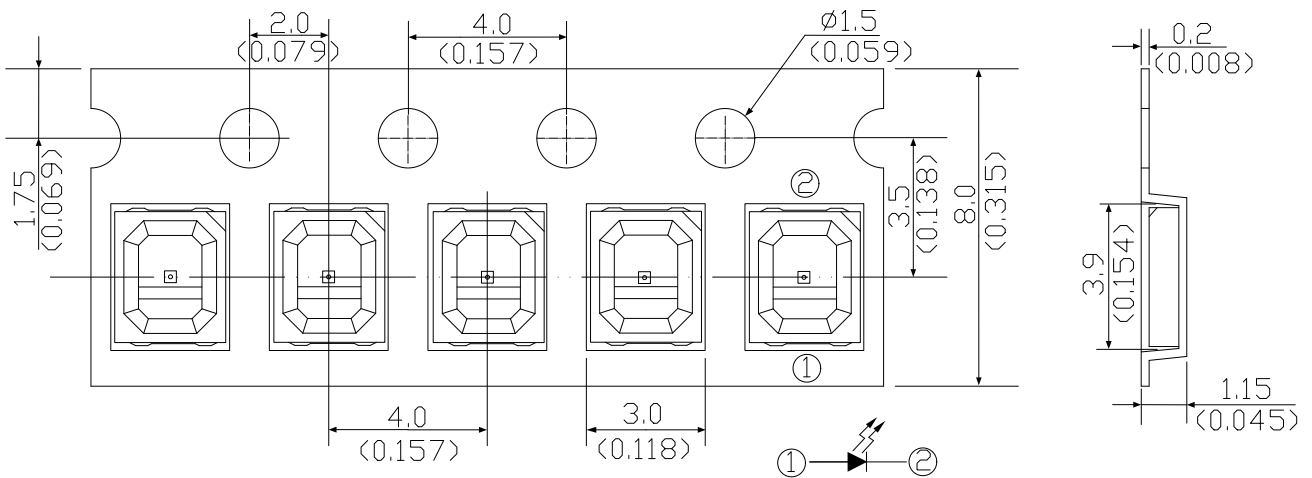

Fig.7 Relative Intensity vs. Ambient Temperature (°C)

Fig.8 Forward Voltage vs. Ambient Temperature (°C)

■ Packing Dimensions



Carrier Tape Dimensions (Quantity: 4000 pcs/reel)



Note: 1. All dimensions are in millimeters(inches)

2. Tolerances unless dimensions $\pm 0.1\text{mm}(.004\text{'})$

① Anode ② Cathode

Notes

1. Above specification may be changed without notice. SHUGUAN will reserve authority on material change for above specification.
2. Before using this product, be sure to test it. The use and storage conditions must not exceed the limit parameters specified in this manual. The company will not be responsible for any damage to the product caused by the use of the product beyond the limit parameters.
3. Stored at a temperature not higher than 30°C and humidity not higher than 60%RH, the product shelf life is 6 months. Keeping the product in an airtight container with a desiccant can extend the shelf life of the product to some extent. Poor storage conditions can cause corrosion of product leads or changes in product performance.
4. After opening, the product must be used within 168 hours (recommended working environment temperature not higher than 30°C , humidity not higher than 60%). If it is not used up, the remaining material must be stored in an environment where the temperature is not higher than 30°C and the humidity is not higher than 10%.
5. For products that have not been soldered, if the hygroscopic agent or packaging fails, or the product does not meet the above valid storage conditions, baking can play a certain performance recovery effect. Baking conditions: $60\pm 5^{\circ}\text{C}$, duration 96H.
6. Static electricity and surges will cause changes in product characteristics, such as forward voltage reduction, etc. If the situation is serious, it will even damage the product, so effective anti-static measures must be taken during use. All related equipment and machines should be properly grounded, and other measures against static electricity and surges must be taken. The use of anti-static wristbands, anti-static mats, anti-static work clothes, work shoes, gloves, and anti-static containers are all effective measures to prevent static electricity and surges.
7. When designing the circuit, the current passing through the product cannot exceed the specified maximum value, and a current limiting resistor must be used at the same time, otherwise a small voltage change will cause a large current change, which may lead to product damage.
8. Welding should pay special attention to:

(1) Manual soldering: the tip temperature of the soldering iron (up to 25W) should not exceed 350° C; the soldering iron must be grounded, and the static electricity should not exceed the range; the soldering time should not exceed 3 seconds.

(2) Reflow soldering

. Pb-free solder temperature profile

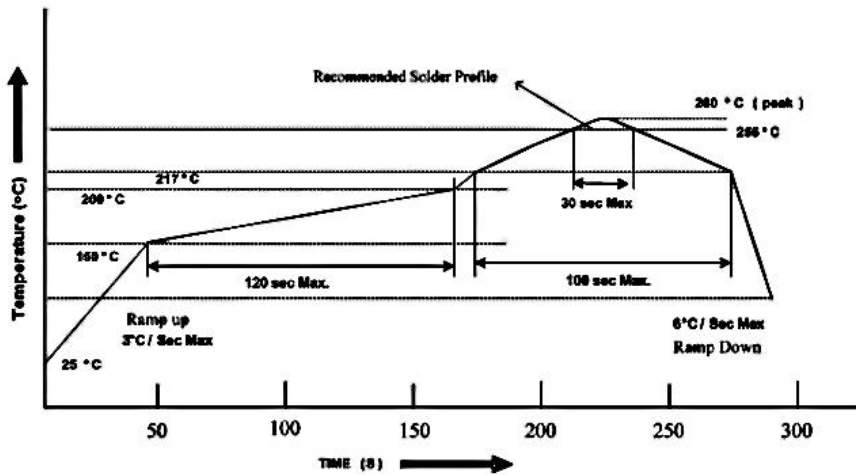

. Reflow soldering should not be done more than two times.

. When soldering, do not put stress on the phototransistor during heating

. After soldering, do not wrap the circuit board.